

Multifeeder Technology®

Feed | Tip | Label | Print | Verify | Glue | Fold | Inspect | Reject | Count | Shingle



When production requirements demand more than a single machine. Multifeeder Technology's experienced engineering department has been designing custom system solutions for over a decade. Small, local companies and large, international corporations alike have brought their production demands and goals to Multifeeder Technology. Whether an operation or application requires the capability to feed, tip, label, print, verify, glue, fold, inspect, reject, count, and shingle, or any combination of these, Multifeeder Technology is a single-source provider of system solutions.

Components That Make a Solution

- **Vacuum Track Conveyor (VTC)** – Sturdy enclosed frame, servo driven conveyor with powerful vacuum pump.
- **Base Feeder** – Operate in continuous, batch count guaranty mode or however your production requires.
- **Tipping Feeder** – Configure one or more feeders to tip additional products to meet your customers requirements.
- **Labeling and Printing**– Add a preprinted label or apply a blank label and ink jet additional information downstream.
- **Folding and Gluing** – Easily incorporate one or more folding/gluing operations onto the VTC frame.
- **Verification and Reject** – Production-level, high speed quality control helps verify only good product passes.
- **Shingling Conveyor** – A perfect companion to the VTC allowing the collection of properly spaced product.

Typical Applications

- **Production Flexibility**
- **Product Fulfilment**
- **Contract Packaging**
- **Gift Card Applications**
- **Labeling Industry**
- **Finishing Industry**
- **Pharmaceutical Industry**

Multifeeder
TECHNOLOGY®

Multifeeder Technology
4821 White Bear Parkway
St. Paul, MN 55110
651-407-3100 www.multifeeder.com

CUSTOM SOLUTION USING STANDARD PRODUCTS

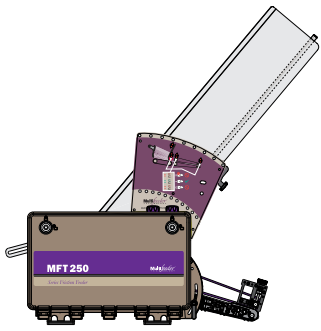

BASE FEEDING

Feeds the base product in batch or continuous mode.

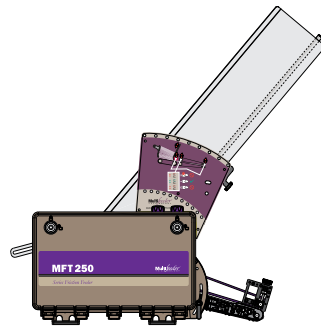

TIP-ON FEEDING

Accurately tips cards, sachets, leaflets and more.

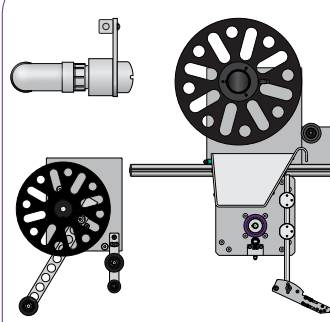

HIGH SPEED LABELING

Add a label, security/hang tag, or even a magnet to your product.

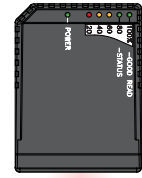

INSPECTION AND REJECT

Verify only *good* product continues to the next stage of production.

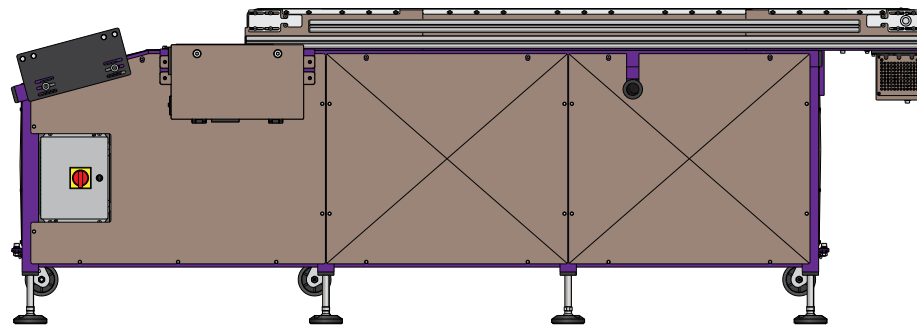

VACUUM TRACK CONVEYOR

A powerful, high speed, servo-driven, computer controlled VTC is the robust system base that integrates all the components of your production solution.

ADDITIONAL AVAILABLE COMPONENTS

- PLC Controls
- Automatic Product Loaders
- Automatic Drop Tables
- Collators
- Catch Trays
- Folder
- Turn Device
- Secure Reject Compartment
- Ink Jet Printers/Dryers
- Data Look-Up and Verification
- Active Count Guarantee

[JUST TO NAME A FEW]

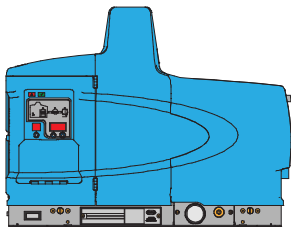

GLUING AND FOLDING

Glue and fold in-line at production speeds.

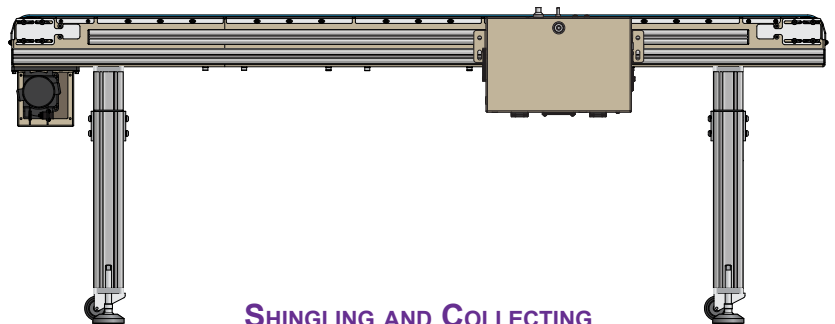

SHINGLING AND COLLECTING

Shingle and collect finished product with an add-on shingling conveyor.